

Inception Controller by Inner Range

P/N: 996300NA / 996300NAPS

V6 Installation Manual North America

(Current to Firmware V6.2 and Controller PCB Rev. F)



**BEFORE COMMENCING INSTALLATION
PLEASE READ THE IMPORTANT NOTES ON PAGE 3
AND THE REGULATORY INFORMATION ON PAGES 4 & 5.**



Document P/No: 636300NA

TABLE OF CONTENTS

| | |
|--|-----------|
| Important Notes | 3 |
| REGULATORY INFORMATION | 4 |
| INTRODUCTION | 6 |
| Features | 6 |
| System Capacities | 6 |
| Parts List | 7 |
| Accessories & Expansion Modules | 7 |
| INSTALLATION | 8 |
| Web connection | 8 |
| Supporting Documentation..... | 8 |
| Location and Housing | 8 |
| Power Supply Options | 8 |
| Service Mode..... | 9 |
| Wireless Devices | 9 |
| Installation and Safety Instructions..... | 10 |
| LED Status Indicators | 11 |
| WIRING DIAGRAMS | 12 |
| Power Supply..... | 12 |
| Output Relays (OUT1 – 4) | 12 |
| Zone Inputs..... | 13 |
| Tamper Input. | 13 |
| LAN & Reader Ports. | 14 |
| LAN and Reader Installation Diagrams. | 15 |
| USB Port..... | 17 |
| Inception Wireless Adapter..... | 17 |
| Alarm Communicator..... | 17 |
| Inception USB Mini-Hub | 17 |
| Alarm Reporting | 18 |
| Reporting Methods..... | 18 |
| SkyTunnel | 18 |
| T4000 Communicator | 18 |
| 3 rd Party Alarm Communicator..... | 18 |
| Report Mapping | 18 |
| TROUBLESHOOTING | 19 |
| PROGRAMMING & MAINTENANCE | 20 |
| Programming and Help | 20 |
| Firmware update..... | 20 |
| Reboot/Default the Inception Controller. | 21 |
| Specifications | 22 |
| Power supply outputs. | 23 |
| Additional Resources | 24 |

Important Notes.

1. Earthing.

To avoid earth loops, ensure that all "0V" terminals on the controller, all LAN and UniBus Modules and peripherals connected to these Modules are NOT connected to an earth point. e.g. A earth lug, the metal enclosure or any other earth connection. Connecting 0V to Earth may create earth loops. When using the supplied MeanWell GST60A24 24V PSU, Inception "0V" terminals are NOT connected to mains earth.

2. Initial Configuration & Installer Username, Password and PIN Code.

- a) On the first access of Inception's web interface the user is taken to the 'Initial Configuration' page to allow you to set your system region, language and time zone. The "Next" button will then take you to the 'Installer Default Configuration' page where the credentials for the Installer user are configured. Setting up secure Installer credentials is required and will need to be done before the user is taken to the login page for the first time. This applies for factory defaulted units, or when the Installer user account has been reset.
- b) A timed lockout is applied to the web interface after the number of failed login attempts, defined in the 'PIN/Password Policy' settings, is reached. Refer to 'Reboot/Default the Inception Controller' in the 'Programming & Maintenance' section for Installer credential reset instructions.

NOTE: Prior to firmware V4.2, the default username/password for web access was installer/installer. The default Installer PIN Code was 01. If still in place, these credentials must be changed to suitably secure strings by the Installer as soon as possible. i.e. As soon as commissioning commences.

3. Sirens.

The Inception controller does not provide dedicated siren outputs for 8 Ohm horn speakers. If connecting a siren to the controller, a piezo screamer or a siren device that includes a built-in driver circuit must be connected to one of the 4 relay outputs. e.g. CSD-1003/CSD-1008 screamers or CSD-1000/CSD-1004 Speaker/Siren combo units. See "Output Relays (OUT1-4)" in the 'WIRING DIAGRAMS' section of this manual. Two dedicated outputs for 8 Ohm horn type siren speakers are provided on 8 Zone LAN Expander Modules.

4. End-of-line (EOL) Resistors.

The inputs on the Inception controller and expansion modules utilize dual end-of-line resistors. The default EOL scheme uses 2k2 & 2k2 or 2k2 & 6k8 resistors. 4 alternate EOL schemes are shown under "Zone Inputs" in the 'WIRING' section.

If Inception is replacing an existing system and the existing detectors are wired with a single EOL scheme or a dual EOL scheme that is not supported, the EOL resistors in the detectors will need to be changed. See the schematic diagram and examples under "Zone Inputs" in the 'WIRING DIAGRAMS' section of this manual.

5. Reporting.

Inception does not provide an on-board dialer port for alarm reporting via PSTN.

Depending on your region and available services, alarm reporting is currently provided by one or more of these methods:

- a) SkyTunnel reporting provides built-in reporting via an internet connection.
- b) T4000 Multipath-IP communicator provides internet & multiple redundant wireless paths.
- c) A 3rd party alarm communicator &/or USB Dialer Modem.

See 'Alarm Reporting' in this manual & 'Inception Tech Bulletin – Alarm Reporting' for details.

6. LAN Expansion.

Expansion modules connected to the Inception controller via the RS485 system LAN, must be connected using appropriate twisted-pair cable. If Inception is replacing another product, any existing LAN wiring may only be used if it meets the LAN cabling requirements described in the 'LAN & Reader Ports' section of this manual.

7. Release Notes.

Inception Release Notes are published for every firmware release. Always read the latest Release Notes for information on changes and enhancements.

8. Fire Protection.

This product must be installed into a suitable non-flammable equipment enclosure ensuring that the enclosure has been installed onto a non-flammable surface and away from all flammable materials. Any Conduit entry points that have had the knockout removed but are not used, must also be resealed using Conduit Plugs.

REGULATORY INFORMATION

UL294 Requirements (North America)

- Wiring methods shall be in accordance with the National Electrical Code (ANSI/NFPA70), local codes, and the authorities having jurisdiction.
- The Inception Controller, remote Modules and UniBus in-cabinet expansion boards are acceptable for indoor use only and must be installed within the protected premises.
- The AC power cord must not be plugged into an outlet controlled by a switch.
- If a separate power supply is utilized for ancillary power (e.g. For electric locks), the power supply must be a UL Listed Access Control or Burglar Alarm, Low-Voltage Class 2, Power-Limited, power source capable of a minimum of 4 hours standby power.
- All cabling must be UL Listed and/or Recognized wire.
- All interconnecting devices must be UL Listed.
- The Inception access control system must be used with UL listed Card Readers.
- The following Listed Card Readers configured for Wiegand or RS485 (OSDP) output are compatible:
 - Inner Range SIFER Reader
 - Inner Range SIFER-Keypad
 - HID iClass
 - HID iClass SE
 - HID Proximity
- Automation. The Automation functionality of this product has not been evaluated by UL.
- FUSES. CAUTION - FOR CONTINUED PROTECTION AGAINST THE RISK OF FIRE, REPLACE WITH ONLY THE SAME TYPE AND RATING OF FUSE.
- Refer to the 'Additional Resources' chapter of this manual for a list of related documentation.

ULC-S304 Requirements (Canada)

- Inception Controller total static load current must not exceed 450mA. i.e. Combined current required by the Controller and devices powered from the LAN+, READER+, V OUT & USB outputs.

UL2610 Requirements (North America)

INSTALLATION NOTES:

- Loss of communication with the monitoring station shall be treated as an alarm condition by monitoring station personnel when the burglar alarm system is in the armed state, and as a trouble condition while the system is disarmed.
- Communication medium between protected property & communications service provider shall be for the exclusive use of the protected property and is not to be shared with other communications service provider subscribers.
- The number of signals in each system used for burglar-alarm signals shall be limited to 1000.
- The central/proprietary/police (monitoring) station equipment shall be designed and constructed so that any critical component can be replaced and the system restored to service within 30 minutes.

PROGRAMMING NOTES:

Message Acknowledge "Acknowledgement signal".

The settings for User acknowledgement of alarm messages are programmed in Configuration > Users as follows:

- In Terminal Profiles > Terminal Permissions, enable the 'System Messages/Warnings' option.
- In Manage Users > Credentials, assign the appropriate 'Terminal Profile' to each User who has a Security PIN.

Entry and Exit Delay: The Entry & Exit delay settings are programmed separately for each Area.

The value programmed for Entry or Exit delay must not exceed 60 seconds.

FCC Statement (North America)

Inception Controller (P/N: 996300NA & 996300NAPS) and Inception USB Wi-Fi Adapter (P/N: 999039)

Information to the user (FCC Part 15.105)

Class B Product:

This equipment has been tested and found to comply with the limits for a Class B digital device, pursuant to Part 15 of the FCC Rules. These limits are designed to provide reasonable protection against harmful interference in a residential installation. This equipment generates, uses and can radiate radio frequency energy and, if not installed and used in accordance with the instructions, may cause harmful interference to radio communications.

However, there is no guarantee that interference will not occur in a particular installation. If this equipment does cause harmful interference to radio or television reception, which can be determined by turning the equipment off and on, the user is encouraged to try to correct the interference by one or more of the following measures:

- Reorient or relocate the receiving antenna.
- Increase the separation between the equipment and receiver.
- Connect the equipment to an outlet on a circuit different from that to which the receiver is connected.
- Consult the dealer or an experienced radio/TV technician for help.

Warning: Any changes or modifications not expressly approved by Inner Range Pty Ltd could void the user's authority to operate the equipment.

ISED Canada

Inception Controller (P/N: 996300NA & 996300NAPS) only.

L'émetteur/récepteur exempt de licence contenu dans le présent appareil est conforme aux CNR d'Innovation, Sciences et Développement économique Canada applicables aux appareils radio exempts de licence. L'exploitation est autorisée aux deux conditions suivantes :

1. L'appareil ne doit pas produire de brouillage;
2. L'appareil doit accepter tout brouillage radioélectrique subi, même si le brouillage est susceptible d'en compromettre le fonctionnement.

CAN ICES-3 (B) / NMB-3(B)

INTRODUCTION

Inception is an integrated access control and intruder alarm system featuring a powerful built-in web server. No computer software is required. System configuration and administration simply requires connecting to a network via Ethernet or Wi-Fi, and using any web browser to navigate to Inception's web page. *See the Quickstart Guide for connection details.*

Features

- USB Connection for Wi-Fi option and/or Alarm Communicator.
- Ethernet port for network connection.
- Support for local HTTPS web access. *See Inception Tech Guide – HTTPS Configuration*
- Tamper input for monitoring of the external enclosure.
- 8 x Universal inputs for security detectors or door monitoring.
- Support for a variety of Input EOL schemes.
- Current-limited 12V DC power outputs for powering external security devices.
- LAN port for system expansion via RS-485.
- Reader port supporting up to 8 Inner Range SIFER, SIFER-Keypad or Mobile Access Readers, or 3rd Party OSDP Readers.
- DC power input for connection to the Inception power supply.
- Battery connection for charging of a back-up battery.
- 4 x Universal relay outputs for locks, alarm sounders, strobes or automation devices.
- Scan the QR code for quick setup of alarm monitoring via SkyTunnel.
- Comprehensive system status LED Indicators.
- 'Send All Possible Alarms' & 'Commissioning Report' features streamline configuration of monitoring station account.
- Web interface and LCD Terminal text displays can be translated into other languages.
- High-level integrations with compatible 3rd party alarm communicator and automation products.
- Support for Intelligent LAN Access Module including Aperio wireless doors.

NOTE: Inception Firmware. To ensure that all features, system capacities, accessory devices and compatible LAN Modules described in this manual are fully supported, check that the Inception Controller firmware is the latest version.

System Capacities

| Entity | Total | On-board Controller | With LAN Expansion |
|-------------------------|----------|---|------------------------|
| Areas | 96 † | | |
| Inputs | 1024 # † | 8 | 1024 |
| Outputs | 1024 # † | 4 * | 1024 |
| Doors | 128 # † | 4 * | 128 |
| Lifts (V1.1.0 or later) | 32 | See V1.1.0 Release notes. | 32 |
| Lift Floors | 1024 # † | 4 * | 1024 |
| SIFER/OSDP Readers | 256 | 8 | 256 (Up to 4 per SLAM) |
| Storage Units | | Dependent on no. of Inputs available and no. of Inputs per unit. <i>Refer to 'Inception Tech Guide – Storage Units' for details.</i> | |
| Wiegand Readers | 256 ‡ | 8 (Via 8 OSDP<>Wiegand Conv.) | 254 ‡ |
| Users | 10,000 † | | |
| Events | 250,000† | | |

Up to 1024 Inputs and 1024 Outputs can be programmed. For Outputs all types of hardware outputs count towards this total including door locks, DOTL, valid & invalid (for wiegand readers), lift floor button enables, siren & strobe outputs, automation devices, etc. (Custom outputs are not counted)
For Inputs, the limit also only applies to hardware Inputs. e.g. Zone, RF Zone, Reed, Tongue, REX, REN & ARM. Tamper Inputs and Calculated Inputs are not counted. e.g. Door Forced, Door Held & Storage Unit Alarm. *See note under 'Report Mapping' for Contact ID input reporting limits.*

* The Inception controller has 4 relay outputs in total. These can be used as lock relays for doors, floor button enable contacts for lifts or general-purpose dry contact outputs.

† Inception Firmware prior to V2.0.0 only supports 32 Doors and 2000 Users.

Inception Firmware prior to V3.1.1 only supports 50,000 Events.

Inception Firmware prior to V4.0 only supports 32 Areas.

Inception Firmware prior to V5.0 only supports 512 Inputs/Outputs/Floors.

‡ 256 Wiegand readers (In & Out Readers) requires a combination of up to 127 SLAMs (i.e. 1 per door) and up to 8 OSDP<>Wiegand Converters.

Parts List

| Main Parts | |
|--|---|
| Inception Security Controller. | Installation manual (This document). |
| Inception Power Supply. 24V DC. 2.5A | Beginners Guide to Inner Range Systems. |
| IEC power cable. Right angle. | Inception Quickstart Guide |
| Accessory Kit (<i>See below</i>) | Inception User Manual |
| Accessory Kit contents | |
| 4 x Metal PCB Mounting Clip. M3. | 3 x 2-way 5mm Screw Terminal. |
| 4 x M3 x 25mm pan head screw. | 4 x 3-way 5mm Screw Terminal. |
| 4 x M3 brass spacer. 8mm. | 3 x 4-way 5mm Screw Terminal. |
| Self-adhesive Hook & Loop tape, 50 x 25mm. | 2 x 6-way 5mm Screw Terminal. |
| 2 x Cable Ties 350 x 4.8mm. | 2 x Female 6.3mm QC Connectors. |
| 20 x 2k2 End-of-line Resistors. | Battery cable pair. 40cm. Red/Black. |
| 4 x 1N4004 Diodes (for locks. *See note below) | Ethernet patch cable. 1m |

NOTE: * See “Output Relays (OUT1-4)” in the ‘WIRING DIAGRAMS’ section of this manual.

Accessories & Expansion Modules

| Optional Accessories | Accessory Part Number | PS Current Required |
|---|--|--|
| Medium Enclosure with Tamper Switch | 995201NA | N/A |
| Sealed Lead Acid Battery. e.g. 12V. 7AH – 18AH | UPG UB1270 CSB HR 1234W F2 | N/A |
| Inception USB Wi-Fi Adapter. Mk II. (Inception Controller Firmware must be V5.0.0 or later) | 999039 (US Only) | 25-40mA (See ‘Specifications’ section) |
| Inner Range SIFER Reader V1.16.0 or later. | 994720 (Standard) 994720MF (Multi-format) | 75mA to 150mA (Depends on LED configuration) |
| Inner Range SIFER-Keypad Reader. | 994725 (Standard) 994725MF (Multi-format) | 75mA to 165mA (Depends on LED configuration) |
| Inner Range OSDP↔Wiegand Converter | 994200 | 20mA (Idle) 35mA (Peak) |
| Inception USB – RS232 Alarm Communicator Interface Cable. | 996798 | Approx. 15mA |
| USB 12V Mini Hub. | 3 rd Party product. | See manufacturers datasheet |
| Integriti 3A battery-backed Smart Power Supply | 996091PCB&K | N/A |
| Integriti 10A PFC battery-backed Smart PS | 996095NA | N/A |
| Replacement 24VDC Adapter | 999066NA | N/A |

| Compatible Expansion Modules | Part Number | Module Firmware | PS Current Required * |
|---|-----------------------|------------------------|---|
| EliteX Keypad EliteX-SIFER Keypad | 995400/CM 995400SI | V3.1.0 or later | 17mA (Idle) 50mA max. 72mA (Idle) 186mA max. |
| 8-32 Zone LAN Expander Module | 996005PCB&K | V3.2.0 or later | 70mA (Idle) 110mA (Both Relays On) |
| Standard LAN Access Module (SLAM) | 996012PCB&K | V4.0.7 or later | 110mA (Idle) 175mA (Lock Relays On) |
| Intelligent LAN Access Module (ILAM). Inception Controller Firmware must be V6.0.0 or later. | 996018PCB&K | V4.1.0 or later | 110mA (Idle) 175mA (Lock Relays On) |
| Inovonics RF LAN Expander Module | 996008 | V1.1.0 or later | 115mA |
| UniBus 8 Zone Expander † | 996500PCB&K | V1.0.3 or later | 75mA |
| UniBus 8 Relay Expander † | 996515PCB&K | V1.1.2 or later | 45mA (Idle) 175mA (All Relays On) |
| UniBus 2 Door Expander † | 996535PCB&K | V1.0.4 or later | 40mA 110mA (Lock Relays On) |
| UniBus 16 Floor Lift I/F Board † | 996540PCB&K | V1.0.0 or later | 310mA (All Relays On) |
| LAN Ethernet Bridge. Inception Controller Firmware V5.2.0 or later recommended. Must be V4.0.0 or later. | 996088PCB&K | V1.1.0 or later | 60mA |

NOTES:

* Does not include current required by detectors, sounders, readers, locks, LEDs and other peripheral devices connected to these modules.

† UniBus expander boards can only be connected to:

- 8-32 Zone LAN Expander Modules
- Intelligent LAN Access Modules (ILAM)

| Module Type | UniBus 8-Zone | UniBus 8-Relay | UniBus 2-Door | UniBus 16-Floor |
|---------------------|---------------|----------------|---------------|-----------------|
| 8-Zone LAN Expander | 3 | 4 | 0 | 6 |
| ILAM | 0 | 1 | 3 | 6 |

Up to 6 UniBus boards in total may be connected to a host LAN Module. A suitable Inner Range Smart Power Supply must be connected to the host Module when UniBus boards are used.

Refer to the relevant host Module & UniBus board Installation Manuals for full details.

INSTALLATION

Web connection

Use any web browser to navigate to Inception's web page.

To connect, navigate to: <https://skytunnel.com.au/inception/SERIALNUMBER>, where SERIALNUMBER is the serial number of your Inception, found on the top of the Controller.

(e.g IN01234567)

See the Quickstart Guide for full connection details.

Supporting Documentation

A list of supporting installation resources and documentation is provided on the last page of this manual. In addition to the documentation provided with each Inception Controller, the downloadable document "Inner Range System Design & Installation Guide" provides a range of general system design & Installation guidelines including additional information on equipment location, power supplies & batteries, wire & cable, tamper protection and installing detectors and warning devices.

Location and Housing

The installation environment should be maintained at a temperature of 0° to 49° Celsius (32° to 120° F) and 15% to 85% Relative humidity (non-condensing).

If not already supplied in an enclosure, the Inception controller must be mounted in an approved Inner Range tamper-protected enclosure such as those listed below. Powered enclosures are available to provide power for additional LAN expansion modules mounted in the same enclosure.

- Unpowered Enclosure 995201NA
- Powered Enclosure 995201NAPS

Power Supply Options

The Inception controller has connections for an 18 to 24V DC Power Supply input and a 12V Sealed Lead-Acid (SLA) Battery. These connections are labelled "DC IN" and "BATT" respectively and allow two power supply options to be supported:

1. Power Supply & Battery (Recommended). The supplied 24V Power Supply is connected to "DC IN" and a 12V SLA Battery is connected to "BATT". A 7AH to 18AH Battery is required depending on battery backup time required. See 'Specifications' section for guidance.
2. External Power Supply. Connect a battery-backed power supply with a nominal output of 12.8V to 14V DC to the "BATT" input. e.g. Integriti 3A or 10A Power Supply (see 'Accessories List' for P/N) or an approved 3rd party battery-backed security system power supply.
NOTE: "DC IN" must not be used.
Ensure that the power requirements do not exceed the power supply's current limit. Remember to allow for the current required by detectors and other devices connected to the Inception controller and other devices that may be powered from the same supply.

Refer to the wiring diagrams and specifications later in this document for more details.

Service Mode

Inception provides a service mode which is enabled/disabled via the web interface or an LCD Terminal. Service mode allows one or more of the functions listed below to be disabled during installation & commissioning or when testing, service or maintenance is required.

| | | | |
|--------|-----------------|-------------------------|-----------------|
| Sirens | Alarm Reporting | Area Alarm Processing * | Door Feedback * |
|--------|-----------------|-------------------------|-----------------|

* V1.1.0 or later only.

In a new controller, service mode is enabled by default for an unlimited amount of time. Once disabled, service mode can be enabled at any time for a limited period.

e.g. When needing to connect to Inception for onsite maintenance, the installer can enable Service Mode from an LCD Terminal, open the controller cabinet and plug in a Wi-Fi Adapter for an access point or an ethernet cable for direct connection to a laptop.

If using the web interface some additional features are provided.

- **Enable:** When enabling, the installer can select which functions to disable and the duration of service mode (1 hour to 1 day).
- **Update:** While running, functions disabled can be updated & the duration timer re-started.
- **Disable:** When disabling, the installer can choose a 'Delay Before Disable' time so that service mode will not be disabled instantly. e.g. The installer can disable service mode with a delay of 10 minutes allowing time for the Wi-Fi adapter or ethernet cable to be removed and the cabinet secured before service mode actually ends.
- **Current Status:** Shows the functions disabled & the service mode expiry date & time.

To Enable or Disable Service Mode.

| Operation | Web Browser | LCD Terminal |
|------------------------|---|--|
| Enable Or Update | -Open 'Service Mode' from the Dashboard or System Menu. -Select 'Enable Service Mode' or 'Update Service Mode'. -Choose which functions to disable and the duration. -Click on "Enable" or "Update". | -Logon, -Press [MENU] [7] [1], -Press [ON] (Enables for 8 Hours) |
| Disable | -Open 'Service Mode' from the Dashboard or System Menu. -Select 'Disable Service Mode'. -If required, choose a 'Delay Before Disable' period. -Click on 'Disable'. | -Logon, -Press [MENU] [7] [1], -Press [OFF] |

Wireless Devices

Inception supports the Integriti Inovonics RF LAN Expander Module that provides an interface for RF detection devices (e.g. Motion Detector, Door/Window Transmitter, etc), general purpose transmitters (for reed switches, etc.) and wireless remote fobs.

When RF transmitter activity is saved to the Inception review log, a signal strength value is included in the message. This allows the installer to assess the relative signal strength of different receiver and/or transmitter locations and the effective range of portable transmitters such as remote fobs.

Note that the signal strength value for portable transmitters (RF fobs) is only available in the Inception firmware release V2.0.2 or later.

Contact your Inception dealer for details of additional Wireless devices that may be supported by Inception in your region.

Installation and Safety Instructions

1. **IMPORTANT NOTE:** An unswitched AC Mains socket-outlet shall be installed near the equipment and shall be easily accessible for connection of the mains power cord.
2. If not already supplied in an enclosure, install the controller in the enclosure. Fit the metal PCB mounting clips into 4 holes in the mounting plate or chassis that align with the mounting holes in the corners of the controller case. Position the controller on the standoffs and secure with the four 25mm M3 screws.
3. The installation kit also provides four threaded brass standoffs. These can be used to raise the position of the mounting plate or the controller if necessary to provide access to the USB and Ethernet connectors.
4. With no power or batteries connected to any device, install all other system components and the system wiring according to the instructions in this manual and other relevant installation manuals.
5. **NOTE:** The Battery is a non-power-limited source. Maintain 0.25in (6.5mm) spacing between Power-limited and Non Power-limited circuits.
6. Before applying power to any device, check all power supply connections and outputs for short circuits.
7. Power up the system and check the LEDs on the controller. Initially the POWER LED will come ON, then after a pause of approximately 20 seconds the other LEDs will light in sequence. When this boot sequence is complete, the SYSTEM LED will flash green to indicate the controller is running. The other LEDs will indicate the current state/condition of their respective operations. *See the table on the following page.*
8. Referring to the Inception Quickstart guide, establish your browser connection and proceed with testing, programming and commissioning the system. The browser provides a “Commissioning Checklist” and details of programming options via info buttons  to assist in this process.
9. The supported web browsers for Inception are:
Chrome; Firefox; Safari; Opera; Microsoft Edge;
Android; iPad/iPhone; Internet Explorer 9 or later.
NOTE: Inception firmware 2.0.0 does not support Internet Explorer or older iOS browsers. Firmware prior to V2.0.0 or from 2.0.2 onwards, does support these browsers; however it is recommended to use a more up-to-date browser.
10. When programming and commissioning of the system is complete, and whenever programming changes are made, use the browser to create a backup of the Inception controller database. Use the “Backup Database” option in the Backup/Restore section of the System options.
IMPORTANT NOTE: Unlike traditional commissioning software programs, the inception browser does not automatically save a copy of the controller database on the PC. You must use the “Backup Database” feature to ensure that a copy of the controller programming is saved.
11. **CAUTION! FOR CONTINUED PROTECTION AGAINST THE RISK OF FIRE, REPLACE WITH ONLY THE SAME TYPE AND RATING OF FUSE. DISCONNECT POWER BEFORE REPLACING THE FUSE OR SERVICING**

LED Status Indicators

The Inception controller has 11 status LED's to quickly identify the current operational status.

| LED | LED State | Meaning |
|-----------|-----------------------------------|--|
| POWER | OFF | No DC IN connected. (Mains not present) |
| | ON Green | DC IN connected (Mains power present) and within nominal voltage range. |
| | Flash 2 Seconds (80% duty cycle) | Battery is present and in nominal voltage range, and battery test is in progress. |
| | Flash 0.4 Second (50% duty cycle) | DC IN is outside nominal voltage range (too high or too low) |
| | Flash 1 second (10% duty cycle) | Internal problem. Return for repair. |
| BATTERY | OFF | No battery connected. |
| | ON Green | Battery connected, within nominal voltage range and no battery test in progress. |
| | Flash 2 Seconds (80% duty cycle) | Battery is present and in nominal voltage range, and battery test is in progress. |
| | Flash 0.4 Second (50% duty cycle) | Battery is outside nominal voltage range (too high or too low) |
| | Flash 1 second (10% duty cycle) | Internal problem. Return for repair. |
| SYSTEM | Flashing Green | Inception controller is running. |
| | ON Red | One or more of the power supply outputs (VOUT) is shorted. Note that the green LED remains flashing which results in an alternating red & orange pattern. |
| SKYTUNNEL | ON Green | SkyTunnel connection is established. |
| ETHERNET | ON Green | An Ethernet cable is connected and Inception has an IP address. |
| ALARMS | ON Red | There are one or more Alarms in the queue to be sent to a monitoring station. |
| WIFI | OFF | No Wi-Fi module present; Or Inception not configured to use Wi-Fi; Or Wi-Fi Adapter is not compatible. See <i>'Accessories List'</i> or contact your Dealer for <i>Wi-Fi Adapter details</i> . |
| | ON Green | Wi-Fi adapter present, and Inception is on Hotspot (Access point) mode. Or, Wi-Fi adapter present, and Inception is connected to a local Wi-Fi network. |
| | Flashing Green | Wi-Fi adapter present. Inception unable to connect to a local Wi-Fi network. |
| OUT 1 | ON Green | OUT 1 is On (i.e. COM & NO connected) |
| OUT 2 | ON Green | OUT 2 is On |
| OUT 3 | ON Green | OUT 3 is On |
| OUT 4 | ON Green | OUT 4 is On |

WIRING DIAGRAMS

Power Supply

OPTION 1.

Supplied 24V PSU and Battery.

Check for correct polarity when installing the supplied battery wires.
 "BATT +" terminal to Battery +.
 "BATT -" terminal to Battery -.

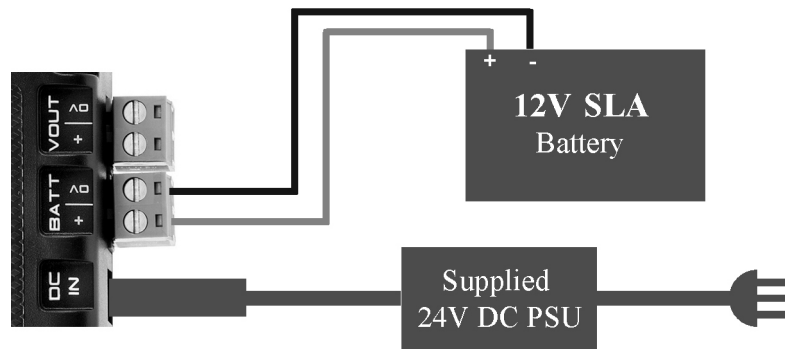

OPTION 2.

Integrati 3A/8A PSU or third party battery-backed power supply.



Output Relays (OUT1 - 4)

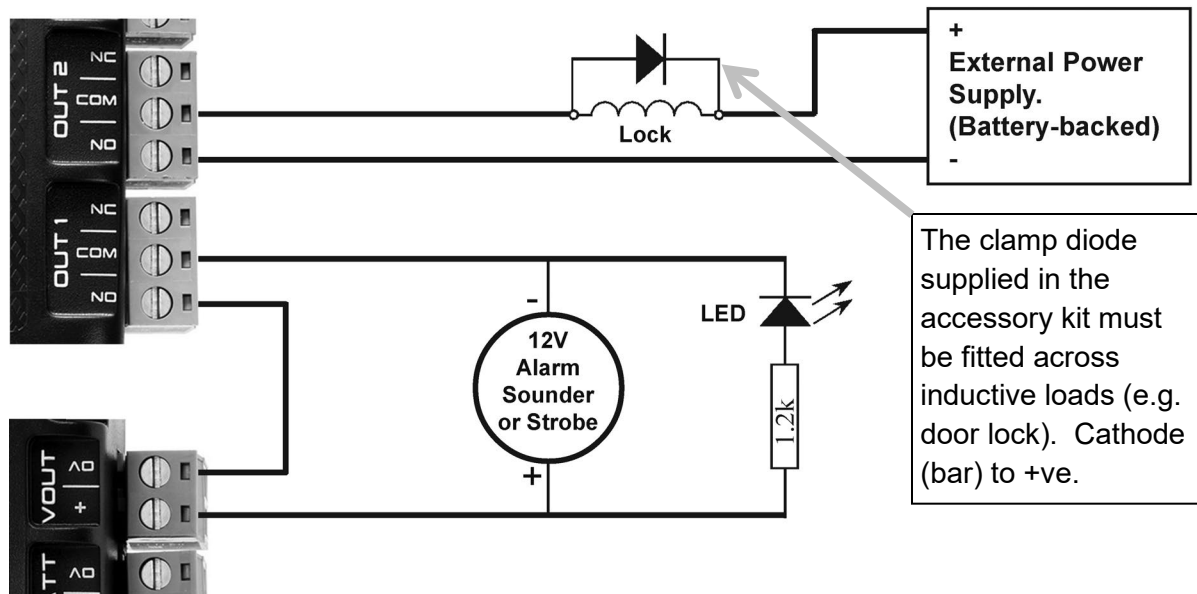

The clamp diode supplied in the accessory kit must be fitted across inductive loads (e.g. door lock). Cathode (bar) to +ve.

Lock or Solenoid Control. An External Power Supply is recommended to power inductive loads to protect the controller, provide longer battery backup & minimise the possibility of earth loops.

Non-Inductive Loads. e.g. 12V Sounder, Beeper, Strobe, LED, etc. The Inception power supply may be used to power these devices. Check that the additional current required by these devices does not cause the Inception power supply output limits to be exceeded.

Zone Inputs.

Eight zone inputs are provided to allow monitoring of detection devices, door reeds, etc. The default EOL configuration is 2k2+2k2 or 2k2+6k8 (shown in the schematic diagram below). A different configuration may be selected. Current options are:

| | |
|--|---------------------------------|
| 1k+1k (Seal=1k / Alarm=2k) | 6k8+3k3 (Seal=6k8 / Alarm=10k1) |
| 4k7+4k7 or 4k7+2k2 (Seal=4k7 / Alarm=9k4 or 6k9) | 10k+10k (Seal=10k / Alarm=20k) |

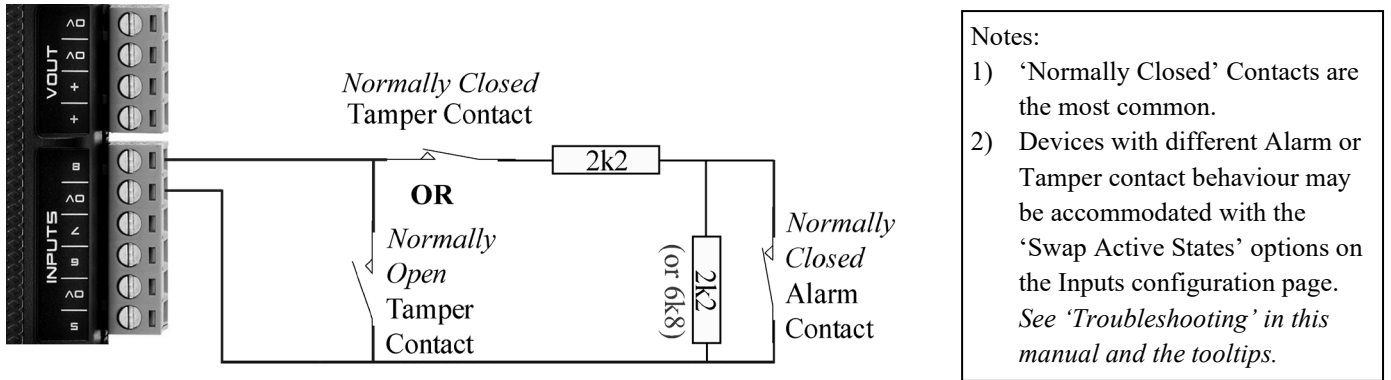

Example: PIR movement detector.

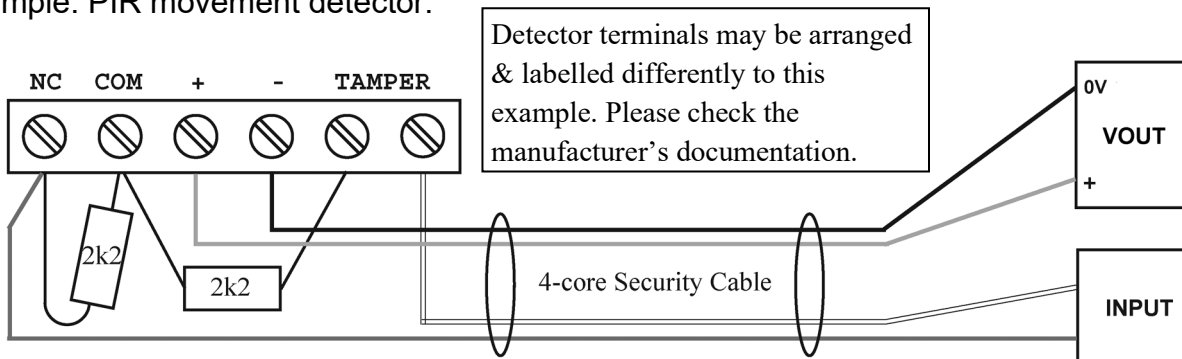

Example: Reed Switch.

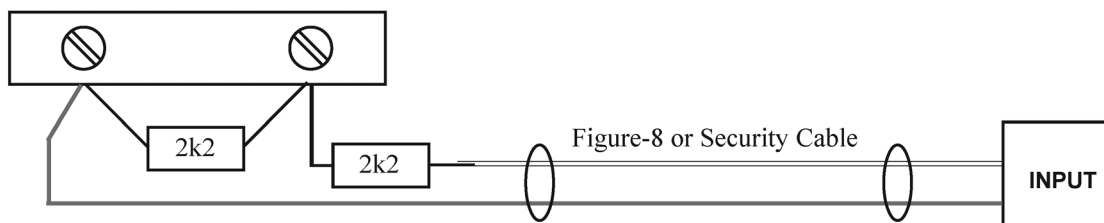

Tamper Input.

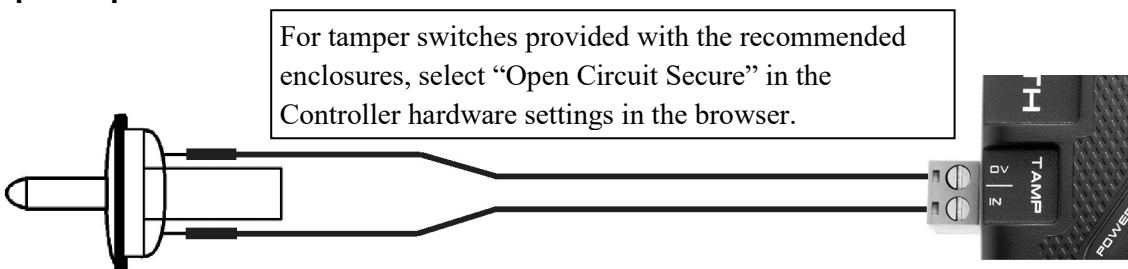

LAN & Reader Ports.

The Inception controller provides two RS485 communication ports:

- The “LAN” port is used to connect LCD Terminals and the LAN Expansion Modules listed under “Compatible Expansion Modules” in the ‘Accessories List’ section.
- The “Reader” port is used to connect Inner Range SIFER Readers or 3rd Party OSDP Readers.

The installation requirements that apply to the “LAN” and “Reader” ports are as follows:

1. Follow all relevant wiring rules and standards.
2. Connections from the RS485 port to the remote devices may be wired in a “daisy-chain” or “star” configuration, or a combination of both within the limits specified below.
3. “A” & “B” connections are wired in parallel across the network using twisted pair cable.
4. The “0V” connection must also be wired to every device.
5. The “+” connection is also used if the device is a Module on the LAN that does not have a local power supply (e.g. LCD Terminal) or if the device is a SIFER or OSDP Reader on the Reader port. The “+” terminal from an RS485 port must not be used to power detectors, relays, etc.
6. Twisted-pair data cable must be used. Shielded, two-pair cable is recommended. e.g. Alpha 2466C/6413, Belden 8723/9842 or UL listed equivalents. Unshielded cable may also be used in suitable electrical environments. e.g. Alpha 1317C, Belden 9744 or UL listed equivalents.
7. Do not use the cable shield as the 0V connection. Shields should be terminated to a protective earth or 0V at one end of the cable
8. A suitable UL listed RS485 Surge Diverter installed at one or more appropriate points on an RS485 network will provide additional system protection, particularly on long runs of LAN cabling and on multi-building installations.
9. A Multimeter may be used to check that the LAN or Reader port will operate reliably. Download the “Inception LAN Installation Guide” from the Inner Range website for details. See ‘Additional Resources’ at the rear of this manual.

Additional installation requirements for the “LAN” port:

- A. The LAN “+” connection used to power LCD Terminals, etc. can be derived from any Module with a local power supply, or from a separate external power supply. However, do not connect the “+” of two power supply sources together. e.g. Controller LAN+, LAN+ from a Module with local power supply or LAN+ from an Integrati 3A power supply.
- B. When wiring the LAN to a Module powered by a local power supply, do not connect the incoming LAN+ wire to the LAN+ connection on the Module.
- C. If a LAN Module deriving its power from the LAN is a large distance from the LAN+ power source (e.g. Controller), it may require a separate local battery-backed power supply &/or heavier gauge cable. e.g. Approx 200m for an LCD Terminal; Approx. 25-50m for other Module types. See *the “Inception LAN Installation Guide” for details*. If a separate power supply is used, do not connect + from the controller LAN port to the Module.
- D. No module is to be more than 4900 feet (1500 metres) cable length from the controller.
- E. Total LAN cabling should not exceed 6500 feet (2000 metres). If the total amount of LAN cable will exceed 6500 ft (2000m) refer to the “Inception LAN Installation Guide” for further information.
- F. Up to 99 Modules of each type may be connected up to a total of 250 Modules. Note that the system capacities (see page 6) will limit the number of modules that may be utilized.

Additional installation requirements for the “Reader” port:

- I. If a Reader is more than 320 feet (100 metres) cabling distance from the controller, it may require a separate local battery-backed power supply &/or heavier gauge cable. See *the SIFER or OSDP Reader installation manual for details*. If a separate power supply is used, do not connect + from the controller Reader port to the Reader.
- II. No Reader, even with an independent power supply, is to be more than 3200 feet (1000 metres) cable length from the controller.
- III. Total Reader cabling on a single RS485 Reader port should not exceed 3200 feet (1000 metres).
- IV. No more than 8 Readers may be connected.

LAN and Reader Installation Diagrams.

The installation requirements are illustrated in the drawings below and on the following page. The characters in square brackets reference the various points in the lists on the previous page.

LAN wiring detail

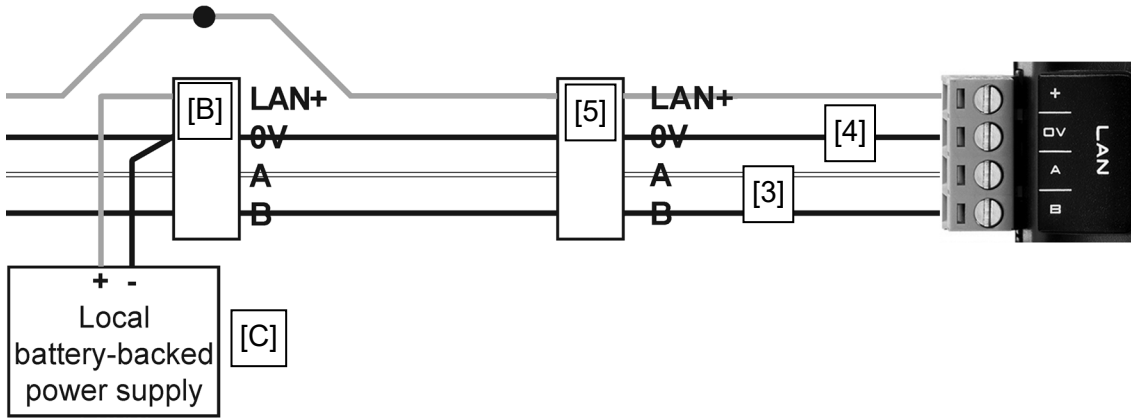

[6] Shielded, twin, twisted-pair data cable

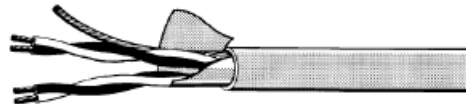

LAN network overview

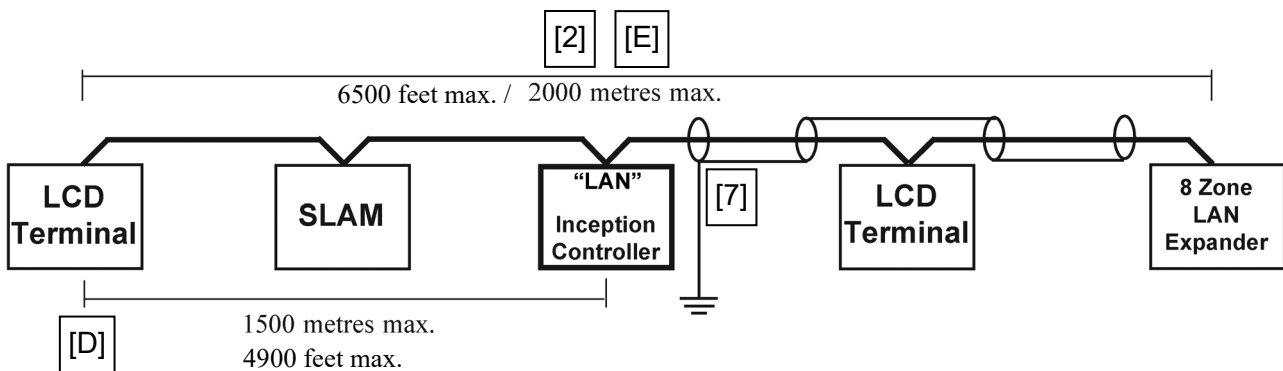

SIFER, SIFER-Keypad or OSDP Reader wiring detail

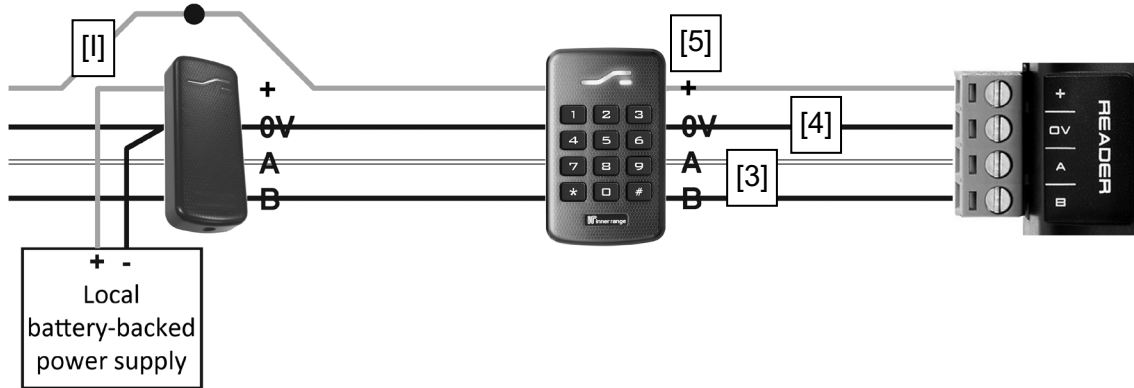

[6] Shielded, twin, twisted-pair data cable

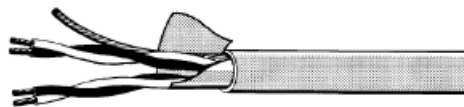

NOTES:

- 1) Other RS485 devices such as LAN Isolators & Fibre Modems must not be connected to the Reader RS485 port.
- 2) If using 3rd Party OSDP Readers, refer to the document 'Inception Tech Guide – OSDP Readers' and the OSDP Reader product installation documentation.

SIFER, SIFER-Keypad or OSDP Reader connection overview

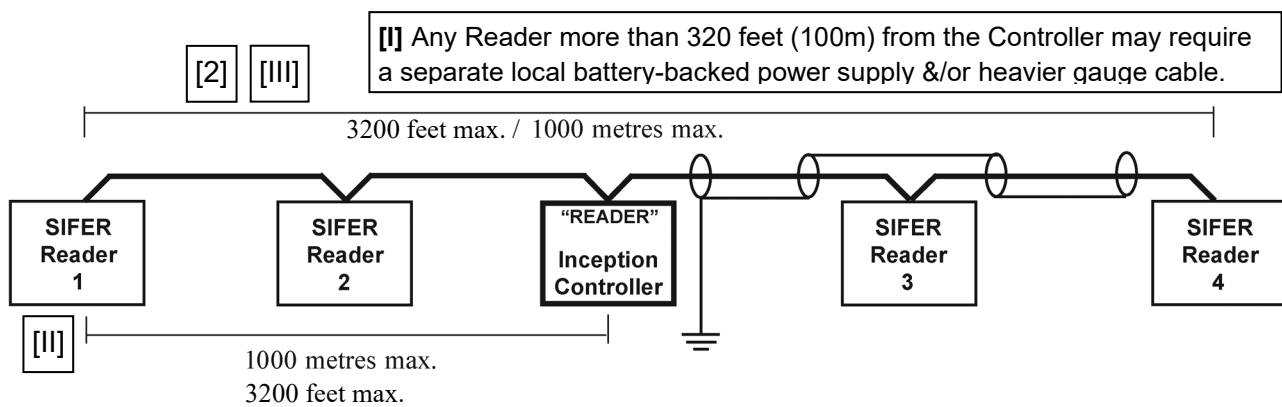

USB Port.

Inception Wireless Adapter

An optional Inception Wireless Adapter can be purchased to provide a convenient wireless connection option with two modes of operation (See 'Accessories List' or contact your Dealer for Wi-Fi Adapter details):

- In Access Point mode, the Wi-Fi adapter can act as a wireless access point allowing installers to establish a temporary wireless connection directly to the Inception controller.
- In Client mode the Wi-Fi adapter can provide Inception with a permanent connection to an existing Wi-Fi network. A magnetic antenna base & extension cable that can be mounted on the outside of the enclosure is included for this purpose.

By default, access point mode is enabled to aid with initial connection and maintenance. The Wireless Adapter is connected to the USB Port. Once connected, wait for the 'WIFI' LED to turn on then you can use your Wi-Fi enabled device to connect to the network.

By default, the name of the Wi-Fi network will be the Inception controller serial number (e.g. IN12345678) with the password "inception". Open a browser and navigate to the URL <http://inception.local> See the Quickstart Guide for more information.

Alarm Communicator

An optional Alarm Communicator (depending on your region) may be connected to the USB port. See the 'Alarm Reporting' section of this manual for details.

Inception USB Mini-Hub

If you need to connect more than one device to the USB Port, (e.g. Both of the devices listed above) an Inception LAN Hub may be purchased to provide up to 4 powered USB Ports.

The LAN Hub is powered from the Inception controller 'VOUT' or from a separate battery-backed 12V power supply. e.g. Integrati 3A Power Supply. **NOTE:** If 'VOUT' is used, then the same 'VOUT' connector should not be used to power any device outside the enclosure.

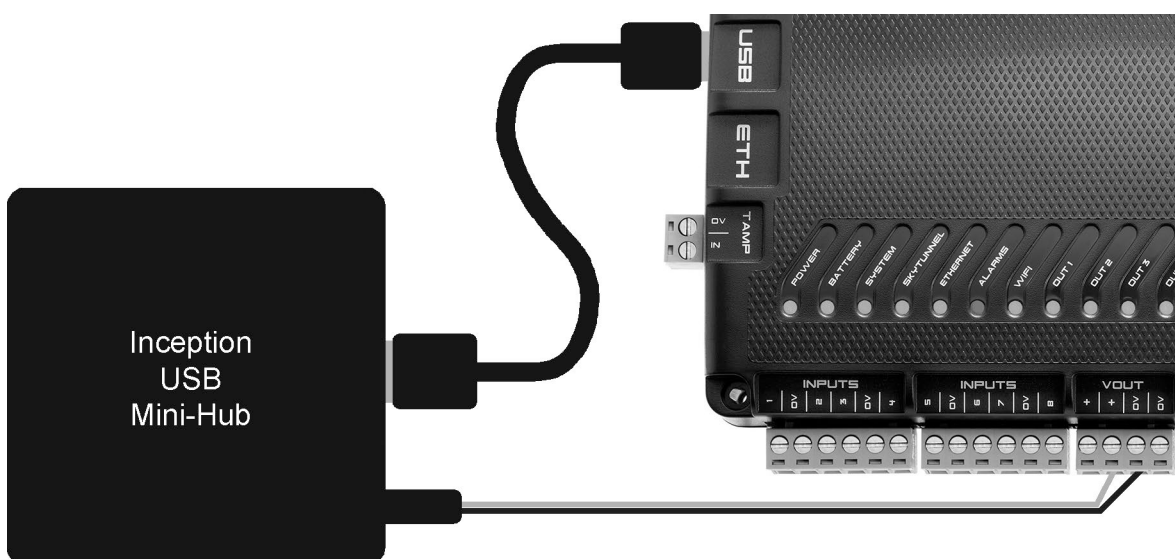

Alarm Reporting.

Depending on your region and available services, alarm reporting may be provided by one or more of the methods listed below. *Contact your Inception dealer for details.*

Alarm reporting typically requires a monthly monitoring plan to be in place with your monitoring station or installer.

Reporting Methods

SkyTunnel

Alarm monitoring can be provided via Inception's SkyTunnel connection. This uses Inception's network connection with internet access to communicate with the SkyTunnel server. SkyTunnel reporting requires no other specialized hardware, allowing reporting directly from the controller in Contact ID or IR-fast formats. When an event is received by the SkyTunnel server it is delivered to a Multipath-IP equipped monitoring station.

SkyTunnel is a cloud-based service provided by Inner Range to deliver hassle free connections of security system hardware and software over the internet. Once the connection is established, set up of the alarm monitoring is quick and easy using the SkyTunnel connection service. *

NOTE: It is not recommended that SkyTunnel reporting be used in conjunction with a T4000 communicator, as doing so will require two account codes with the Central Monitoring Station.

T4000 Communicator

A T4000 Security Communicator can be connected to the USB port on the Inception controller to send IP alarms to a Monitoring Station in Contact ID or IR-fast reporting formats. *

T4000 can provide multiple redundant polled reporting paths using multiple 3G networks in addition to ethernet internet reporting to ensure reliable alarm monitoring. Both reporting paths can be configured for Periodic Test Reports to ensure that communication to the monitoring station occurs successfully in the absence of alarm events. Inception supports both of these reporting paths at the same time to provide redundancy. You will need to select a plan based on your preferred method of primary and backup communication paths. The T4000 and the Inception-T4000 interface cable are purchased separately. *Refer to the 'Accessories List' for part numbers.*

NOTES:

- 1) The power supply source used to power the T4000 (e.g. An Inception Controller 'VOUT' port) should not be used to power any device outside the same enclosure.
- 2) The T4000 must be configured to 'Concept/Integriti GSM protocol' by the central monitoring station using the Multipath-IP Client software.

3rd Party Alarm Communicator

Depending on your region, a 3rd Party Alarm Communicator may be connected to the Controller USB port to send alarms to a Monitoring Station. *Contact your Inception dealer for details.*

* A valid SkyTunnel or T4000 monitoring plan also allows internet access to Inception's web page.

Report Mapping

The Inception browser allows you to download a Contact ID Commissioning Report containing all input, user and area reporting IDs, as well as all input and module states that can be sent.

Use the "Contact ID Report" button in the Alarm Reporting section of the General options in the Configuration menu. Two types of reports are available:

- A 'Full Report' contains a list of everything that can be reported.
- A 'Changes + Full Report' will show a list of all updates and deletions since a previous report was run, then the full report afterwards.

The report is provided as a CSV file and can be useful for a monitoring station to create/update the mapping for the site and as a useful record for the installer.

NOTE: For Contact ID format, only 512 inputs can be individually reported. Inputs above this number will report on point ID 999. Point ID 513 to 998 are reserved for Module Health reporting. IRFast format is recommended for individual reporting on all Inputs.

TROUBLESHOOTING.

If any problems are experienced during installation please check this troubleshooting guide for possible causes and suggested solutions.

| Problem | Possible Causes | Solution |
|--|--|---|
| System LED is RED | The VOUT, LAN or READER positive (+) & negative (0V) are shorted. | With the Inception panel powered, disconnect all VOUT, LAN & READER connections. Re-connect them one by one checking that the System LED remains flashing Green after each connection. If the System LED returns RED after plugging in one of the above, there is a fault/short in the wiring of that power circuit. |
| Sirens sound after disabling Service Mode. | <ul style="list-style-type: none"> • An area is armed with unsealed inputs. • An input in an area is in the tamper state. • The controller or a module is detecting a tamper (cabinet or siren) | Navigate to the Control Inputs page in the web browser & look for inputs that are in the tamper or alarm state. Navigate to the View Hardware page & verify the state of the modules. If any modules are indicating tampers, fix the issue or navigate to the Hardware page & edit the module to not monitor that tamper on the Additional Components section of the wizard. |
| Alarm LED is on | The configured alarm reporting paths are incorrect & Alarm events cannot be sent via a network path to the monitoring station. | Ensure a monitoring station account is configured for this device. If reporting via SkyTunnel, navigate to Network Settings & ensure that the Ethernet, Wi-Fi & Skytunnel settings are configured correctly. |
| Wi-Fi LED is turned OFF when the Wi-Fi Adapter is plugged in. | Wi-Fi has been disabled on the Network Settings page, or the adapter is not an approved Inception Wi-Fi Adapter or is not supported in the Controller firmware. | Navigate to Network settings & check that Enable Wi-Fi has been selected. Ensure the correct Wi-Fi Connection mode type is selected. Ensure that an authorized Inner Range Inception Wi-Fi Adapter is connected and is supported. Upgrade firmware to V5.0.0 or later. See 'Accessories List' or contact your Dealer for Wi-Fi Adapter details. |
| Skytunnel LED is OFF/Unable to connect to Inception panel via Skytunnel | No Internet Access. Skytunnel connection has not been correctly configured | Confirm the network has internet access. Navigate to Network settings & ensure that Enable Web Access over Skytunnel is checked. |
| Strobes or sirens are not functioning correctly. | The connected siren wiring is shorted/not connected or is not configured correctly. | Navigate to the Area Test page & manually test the sirens. For those that do not work correctly, ensure the area configuration is correct then check wiring. |
| Unable to login with any user, or access is restricted with all users. | The installer user credentials were lost, or a web profile change has limited everyone's access | Perform an Installer User Password reset. |
| Review Events &/or time scheduling is wrong or appears out of order. | <ul style="list-style-type: none"> • Date & Time Settings are incorrect • The time has been manually set or the configured NTP server is not configured correctly. | Navigate to the Date & Time configuration page. In order to set the time manually, click "Set Date/Time Manually". Once the dialog box appears either set the time using the calendar or by clicking the "Get time from browser". This will sync the inception panel's time to that of the device being used to setup the system. |
| The input states are backwards (active when it should be secure & vice-versa). | a) EOL Resistors are incorrectly wired. b) The device's output is Normally Open for secure & closes for the active state. | If 'a)', rectify EOL wiring. If 'b)', configure the Input as normal, then navigate to the Inputs configuration page, select the input and set 'Swap Active States' to "Swap Active & Secure States". |
| The active and tamper input states are backwards. | a) EOL Resistors are incorrectly wired. b) The device requires the active & tamper states to be flipped. | If 'a)', rectify EOL wiring. If 'b)', configure the Input as normal, then navigate to the Inputs configuration page, select the input and set 'Swap Active States' to "Swap Active & Tamper States". |

PROGRAMMING & MAINTENANCE.

Programming and Help

The information field and the info buttons  provided in the web browser pages provide details of the system entities and programming.

Note: Click on “Read more...” to see the full contents of an information field. Click on “See Less...” to minimize.

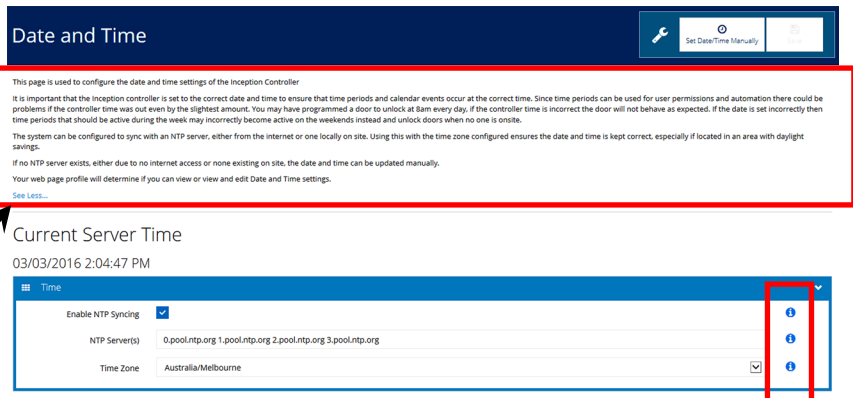

Firmware update

The Inception controller and LAN Modules can be updated to the latest firmware version from the browser.

Use the “Update Controller” or “Update Modules” selections in the Firmware Update options under “System”. *See screen below.*

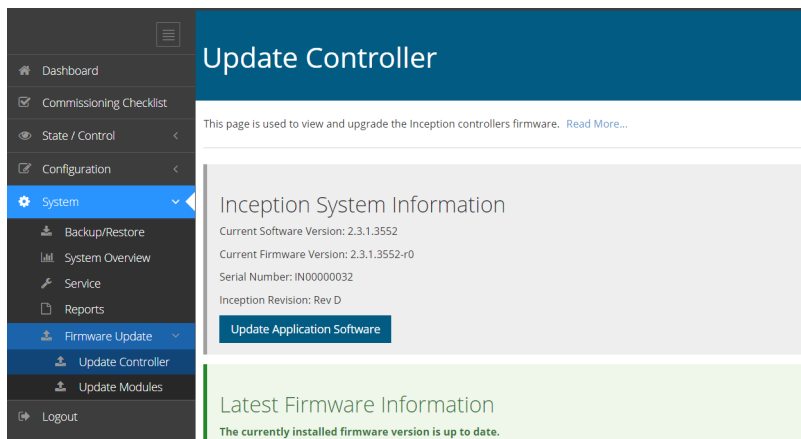

Firmware update files are available in the Technician Downloads section of the Inner Range website.

Reboot/Default the Inception Controller.

An Inception controller can be reset and/or defaulted by two methods:

- 1) By pressing the reset button on the unit with a paper clip or pin as described below.

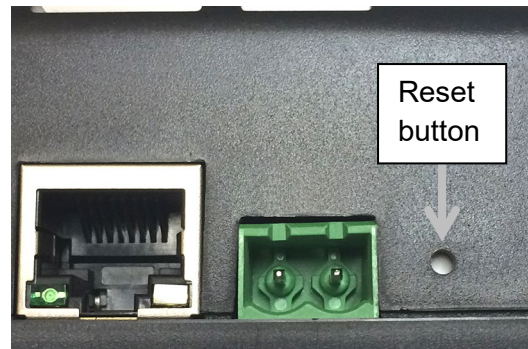

| Reset button action | Operation | Feedback |
|---|---|--|
| Single short press. | Reboot the Controller. No settings or programming are changed. | Single beep. |
| Press and hold for 5 seconds. | Factory default. All settings and programming are restored to the factory default including installer codes and logins. Controller is rebooted. | Single beep at start and higher pitched beep at end of 5s button press. |
| Press 5 times in quick succession. (5 presses within <u>less than 5 seconds</u>) | Installer reset only. The installer code, web profile and permissions are reset or re-created. Controller is rebooted. | 5 beep sequence with last beep higher pitch. If the fifth beep is not a higher pitch, only a normal reboot will occur. Wait for reboot to complete, then repeat the 5 button presses a little faster. |

- 2) The Inception controller can be reset to the Factory Default settings from the browser. Use the "Reset to Factory Default" button in the Backup/Restore options under "System".
See screen image below.

Note: If reset using this option, Review and System Log will not be removed. To remove these items use the Reset button option instead.

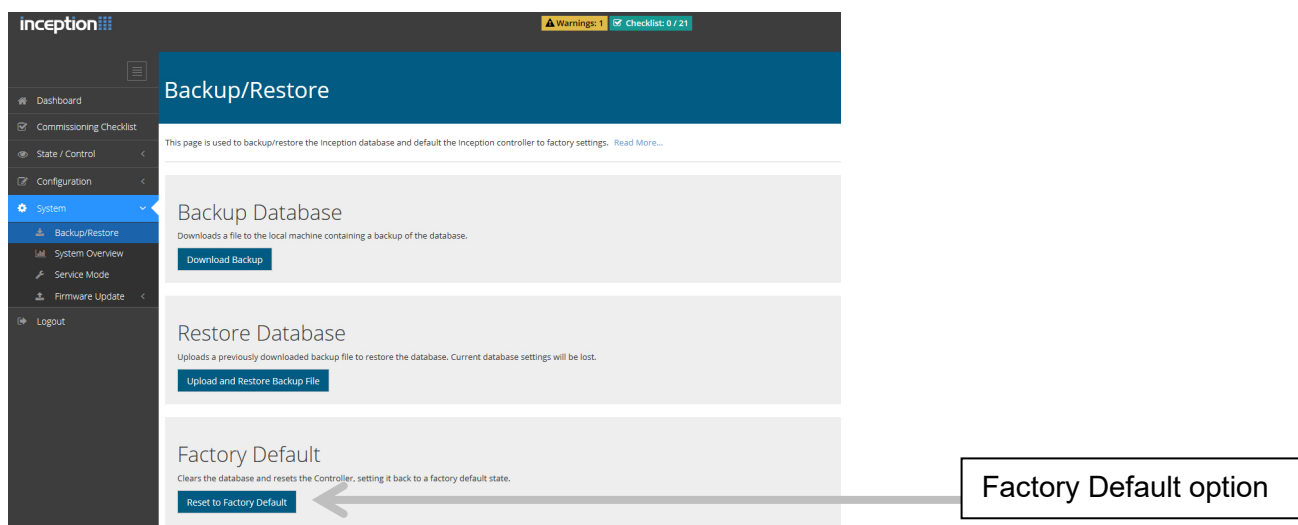

Specifications

| | |
|---|--|
| Case Material: | ABS plastic. |
| Dimensions: | 205mm / 8.1" x 94mm / 3.7" x 38mm / 1.5" |
| Shipping Weight (gross): | 1.2kg / 2.65lbs |
| Installation environment: | 0° to 49° C / 32° to 120° F. @ 15%-85% relative humidity (non-condensing) |
| Power Source. -To "DC IN" (Recommended): -To "BATT" (Alternate method): "DC IN" not connected. | 18V to 24V DC. 2.5A. e.g. The supplied 24V 2.5A PSU. Note: 12V, SLA Battery of 7AH to 18AH capacity must be connected to 'BATT' input. 12.8V-14V DC. 2.8A. i.e. A separate external battery-backed power supply is used. |
| Battery: | 12 Volt Sealed Lead-Acid (gel) type. 7 to 18 Amp-Hour. |
| Idle current consumption. -DC IN = 24V DC: -BATT ("DC IN" = 0V): | Note: Does not include Battery charging or current required by any peripheral devices. 60mA (85mA with Ethernet connected) 110mA (150mA with Ethernet connected) |
| Additional current required for: -Built-in Relays (OUT1 – OUT4) -Inception Wireless Adapter: -4-Port USB Hub with 12VDC input: | 25mA per relay. (33mA when Controller powered from 'BATT' i/p) 25mA (40mA when Controller powered from 'BATT' i/p) See manufacturer's datasheet. Must be powered via 12VDC input, <u>not</u> the Inception USB port. Allow for current required by any device connected to a USB Port. |
| Power supply outputs. | See Separate Table On The Following Page. |
| Battery Charger output voltage: | 13.75V DC. |
| Battery charger output current: | Up to 500mA. |
| Typical Battery Backup Time. 7AH Battery: 18AH Battery: 18AH Battery: | Controller connected to Ethernet <u>or</u> Wi-Fi + 1 LCD Terminal + up to 200mA for other devices (PIRs, communicator, reader, etc.). 16 Hours. 40 Hours. Configuration as above but up to 500mA for other devices. 24 Hours. |
| Typical Battery Recharge Time. 7AH Battery: 18AH Battery: | To full charge after providing backup at the loads specified & periods listed above. 18 Hours 42 Hours |
| AC Fail detect (On "DC IN"): | 16.5V DC |
| Low battery detect (On "BATT" I/P): | 11.0V DC |
| Output Fuses: | Individual PTC protection, self-resetting. |
| Battery Input Fuse: | 7A. Non-replaceable. If blown, unit must be returned for repair. |
| Battery deep discharge protection. | Activated: 10.4V Restored: 12.5V |
| Battery replacement period: | 5 years max. 3 years typical. <i>Refer to battery manufacturers recommendations & relevant local standards.</i> |
| Zone inputs: | 8 |
| Relay outputs: | 4 ('OUT1-4') |
| Relay contact rating: | 5 Amps. 30v DC or AC. <i>See Note 3 below.</i> |
| USB version: | 2.0 |
| Alarm Reporting Formats: | Contact ID. IR-fast. (via T4000 or SkyTunnel) |

Power supply outputs.

NOTES:

1. The Inception Controller PCB Revision can be viewed via one of the following methods.
 - LCD Terminal: Logon as Installer. Press; MENU, 5, 1, then use the 'V' key to scroll to the screen showing 'PCB Revision ^v'. The PCB revision will be shown on the bottom line of the display.
 - Browser: Logon as Installer. Select; System > Firmware Update > Update Controller. Under the heading 'Inception System Information', see 'Inception Revision: Rev ?' for the PCB revision. See "Firmware Update" in the 'Maintenance' section of this manual for an example.
2. See the "Parts & Accessories" Lists in this manual for details of power supply current requirements of the accessories and expansion modules that may be powered from the Inception controller power supply.
3. A separate external battery-backed power supply may be required for devices connected to the Inception controller if the current required is in excess of the maximum current allowed for that power supply output, or causes the maximum combined output current specification to be exceeded.
4. Actual combined static load current should be kept to a value that achieves the required battery backup & recharge times. The system designer/installer must ensure that the normal load current values and battery capacity are chosen to ensure that the battery can be re-charged adequately within the required time, considering the 500mA Battery charging current limit. See 'Specifications' above & 'Regulatory Information' for more details.
5. Devices powered from these outputs must be rated to operate with a power supply of up to 14 VDC.

| OUTPUT | VOLTAGE | MAXIMUM CURRENT See Notes 1 & 4 above. | |
|---|---------------------|---|---------------------|
| | | PCB REV. A or B | PCB REV. D or later |
| USB: | 5 V DC | 500 milliAmps | |
| LAN +: | 13.4 V DC. +/-150mV | 350 milliAmps | |
| V OUT: 2-pin connector near 'BATT' | 13.4 V DC. +/-150mV | 1.5 Amps | |
| V OUT: 4-pin connector near Inputs. | 13.4 V DC. +/-150mV | 750 milliAmps | 1.5 Amps |
| READER +: | 13.4 V DC. +/-150mV | 1 Amp | 1.1 Amps |
| Maximum combined peak current from these 5 outputs: | | 2.5 Amps | 3 Amps |

Additional Resources

Web.

<http://www.innerrange.com/>

- Use the 'Products' & 'Solutions' menus for general product information.
- Use the 'Products' menu for downloads including the documentation listed below and firmware updates.
- Use the 'Training' menu for information on Inner Range certified training.

Documentation. (From the 'Training & Support' menu on the website)

- Product Information and User Manuals. (*Select the product, then the "Documents" link*)
 - Inception Colour Brochure (12 pages)
 - A Beginners Guide to Inner Range Systems. (Inner Range 101 Guide)
 - Inception Controller Data Sheet.
 - Inception User Manual.
- Installation, commissioning and maintenance. (*Select the product, then the "Documents" link*)
 - Inception Security Controller Installation manual (this document).
 - Inception Quickstart Guide.
 - Inception LAN Installation Guide.
 - Inception USB Wi-Fi Adapter Installation Manual.
 - Inner Range System Design & Installation Guide.
 - Inception System Alarm Contact ID Map.

 - Inception Release Notes.
 - Inception Tech Bulletin – Automation Interface.
 - Inception Tech Bulletin – Alarm Reporting
 - Inception Tech Bulletin – Door Interlocking
 - Inception Tech Guide – HTTPS Configuration.
 - Inception Tech Guide – Storage Units.
 - Inception Tech Guide – DUIM (Dynamic User Import Module)
 - Inception Tech Guide – OSDP Readers
 - Inception Tech Guide – ILAM Offline Guide
 - Inception Tech Guide – Aperio Wireless Doors
 - Inception Tech Guide – IR Mobile Access
 - Inception Tech Guide – Licensing

 - EliteX LCD Keypad Installation manuals.
 - Integriti SIFER Smart Card Reader / SIFER-Keypad Installation manuals.
 - Integriti Expansion Module installation manuals. (SLAM, ILAM, 8-Zone Exp., RF Exp. etc.)
 - Integriti Power Supply installation manuals.
 - Integriti Enclosure installation manuals.
 - Integriti-Inception Inovonics RF Expander Application Note.pdf

Disclaimer:

1. The manufacturer and/or its agents take no responsibility for any damage, financial loss or injury caused to any equipment, property or persons resulting from the correct or incorrect use of the system or its peripherals. The purchaser assumes all responsibility in the use of the system and its peripherals.
2. While every effort has been made to ensure the accuracy of this manual, the manufacturer assumes no responsibility or liability for any errors or omissions. Due to ongoing development, product specifications and the contents of this manual are subject to change without notice.